

ECO1850BO

Product description: cylindrical 1850 litre bunded oil tank

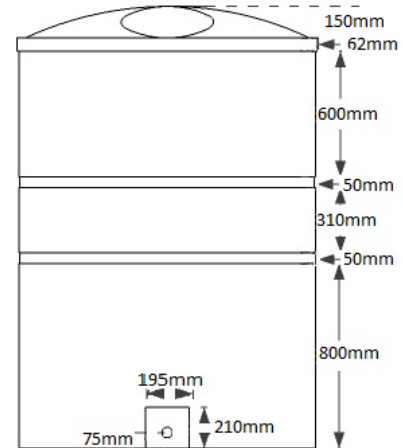
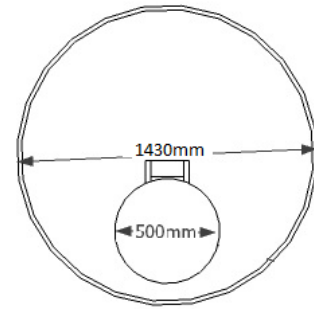

Minimum Base Required
Diameter
2030mm

Product Information

Height	Diameter	Outlet	Fill Point	Weight	Security
2022mm	1430mm	1" BSP bottom	2" overfill prevention valve	125kg	Lockable lid

Sizes approximate, owing to shrinkage

PRODUCT DETAILS:

- Suitable for the storage of Kerosene (C1/C2), Fuel Oil (A2) and GasOil/Diesel (D) as defined in BS2869 and BSEN590 including up to 10% biofuel to BSEN14214
- Bund contains minimum 110% volume of the inner tank
- Made from UV stabilised virgin polymer
- Designed and manufactured in the UK
- Bunded oil storage to protect the environment
- 4" inspection cap

OPTIONAL EXTRAS:

- Alarms
- Filter valve pack
- Electronic level gauge
- Bund alarm
- Tigerloop and Tigerloop Kit
- Spill kit
- Fire valves
- Qual oil pipe
- Top outlet
- Colour options (Ecostone range)

BENEFITS:

- Economical high capacity oil storage
- Suitable for domestic, agricultural, & industrial use
- High impact strength
- Bunded construction offers integral protection from leakage and overfilling
- Covered bund prevents collection of rainwater & debris
- Rotationally moulded for strength and durability
- 10 year warranty against manufacturing defects



Scan to view our full range of oil tanks



Etills Ltd
Unit 1 Whiting Way,
Melbourn,
Royston,
SG8 6NA

Tel: 01763 261781
Fax: 01763 268409